



Enriching Lives

KIRLOSKAR HVAC PUMPING SYSTEMS

COMFORT WITH SAVINGS & SUSTAINABILITY



AIR CONDITIONING • HEATING • ENERGY MANAGEMENT

KIRLOSKAR BROTHERS LIMITED

A Kirloskar Group Company

Established 1888

About Kirloskar Brothers Limited

Kirloskar Brothers Limited (KBL) is the flagship company of Kirloskar Group. Established in 1888 and incorporated in 1920, KBL is the largest manufacturer and exporter of pumps, valves and pumping systems in the country.

Pumps ranging from 0.18 kW to 26,000 kW

- Projects and Engineered Pumps
- Infrastructural Pumping Projects
- Industrial Pumps
- Agricultural and Domestic Pumps
- Valves
- Motors
- Hydroturbines
- Alternators



Smallest Pump



Biggest Pump

KBL proud manager standing at the discharge pipe of KBL's large pump and holding KBL's smallest pump



Manufacturing Unit at Kirloskarvadi
Celebrating **100 YEARS** (1910-2010)



'YAMUNA', Global Headquarters of Kirloskar Brothers Limited is among the Greenest Buildings in India with LEED Certified Platinum Rating

KBL Comprehensive Solution to HVAC Industry

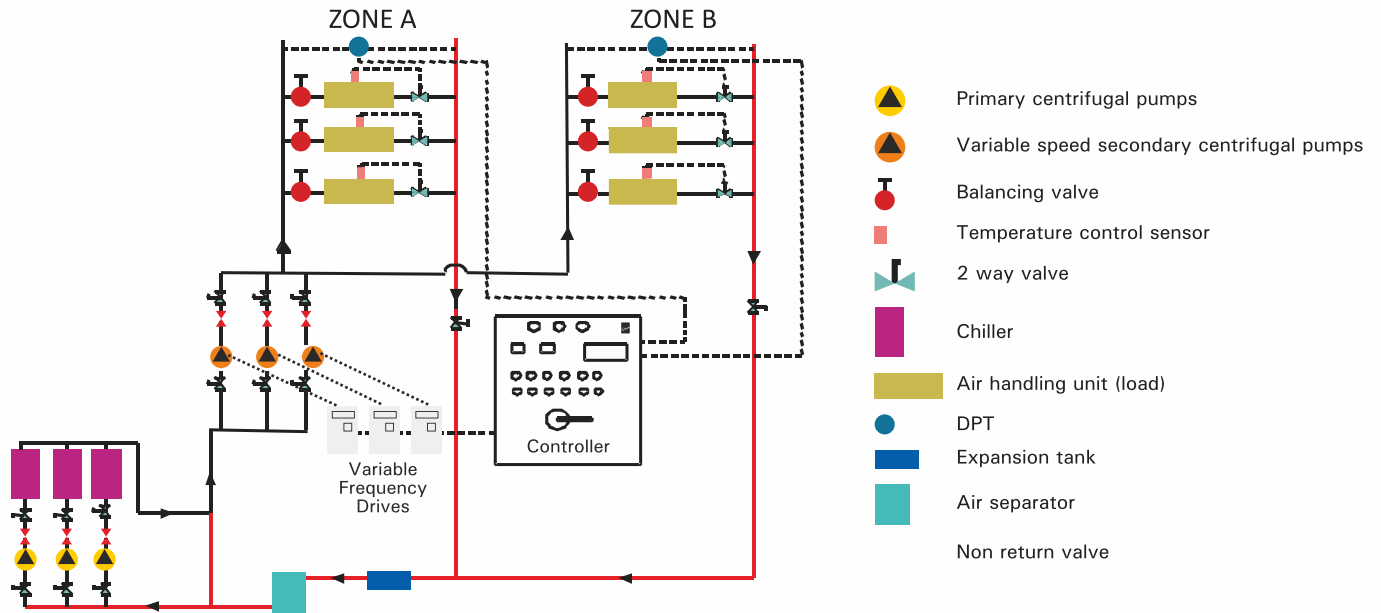

Our Offerings:

- Primary and Condenser Pump Sets
- Secondary Variable Speed Pumping System
- Tertiary Variable Speed Pumping System
- Primary Variable Flow System
- District Cooling System



Listed - Packaged Pumping System



Approved – Pumps

Offerings

Pumps	Long & Short Coupled Pumps, Single & Double Suction Pumps Vertical Inline Single & Multistage Pump
Motors	EFF2, EFF1 & Higher Efficient
Control Panel	Wall & floor mounted panels
Energy Saving and Efficiency Sustainable Coatings	Glass flake coating on Pumps, Valves, Tanks, Pipes etc.
Accessories	Valves, Differential Pressure Transducers, Condition Monitoring System, Expansion Tank, Air Separator Tank, Pressurisation System
Service Backup	24x7 Service Backup, Energy Audit, O&M Contract, etc.

Primary Variable Flow Pumping System

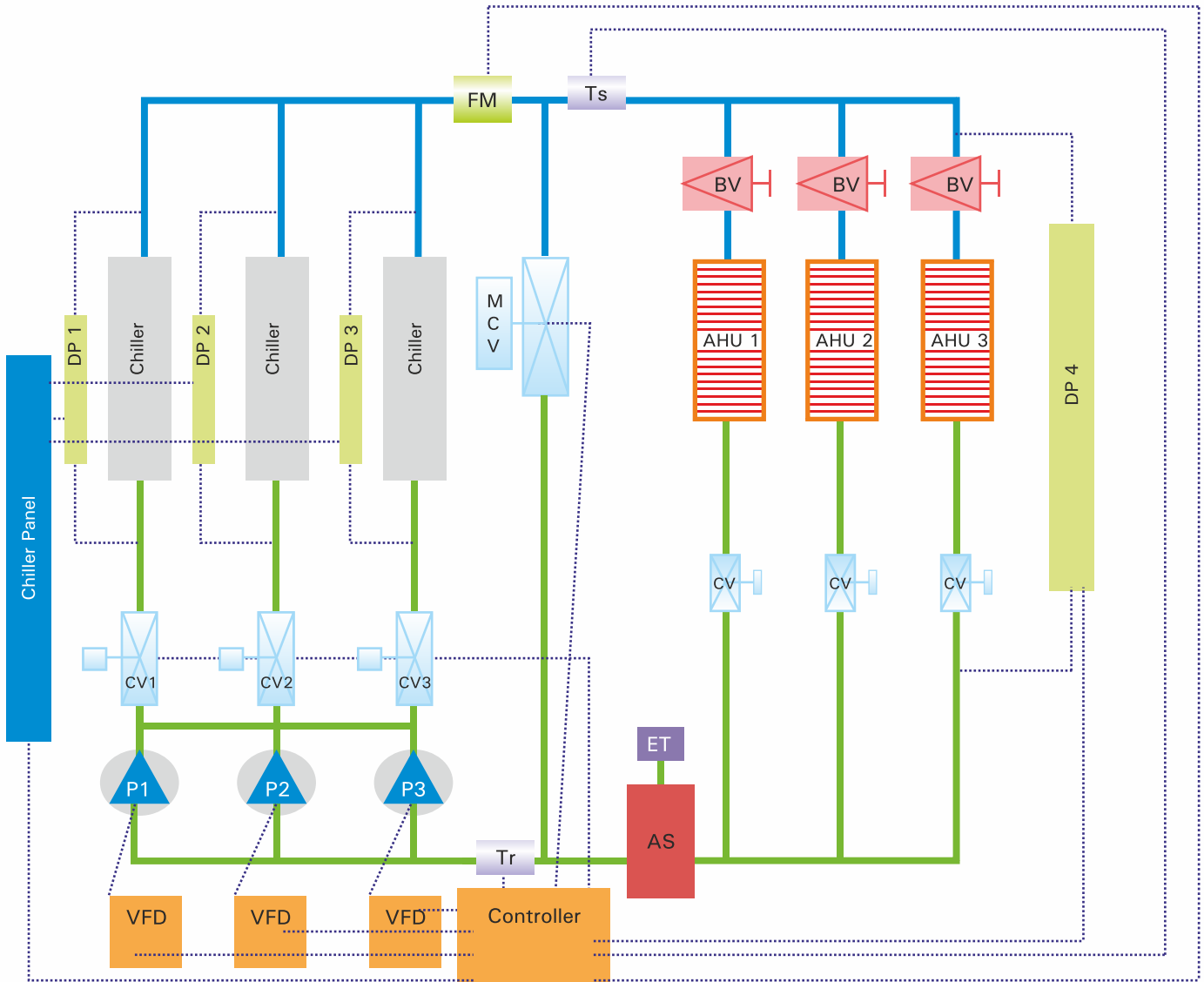

Notifications-

- | | | | |
|---------------------------|---------------------------------|---------|----------------------------|
| FM | : Flow Meter | MCV | : Modulating Control Valve |
| P1 | : Pump 1 | P2 | : Pump 2 |
| P3 | : Pump 3 | VFD | : Variable Frequency |
| AS | : Air Separator | ET | : Expansion Tank |
| AHU | : Air Handling Units | Ts / Tr | : Temperature Sensors |
| BV | : Balancing Valve | | |
| DP 1 / DP 2 / DP 3 / DP 4 | : Differential Pressure Sensors | | |
| CV / CV 1 / CV 2 / CV 3 | : Control Valves | | |

About Primary Variable Controller



Controller Features

- It is a specially designed modular controller for Primary Variable Flow System
- Standard I/Os are as below-
 - a) Analogue Inputs-12 Nos & Analogue Outputs-2 Nos
 - b) Digital Inputs-24 Nos & Digital Outputs-16 Nos
- However, digital and analogue input / output capability can be extended up to 1024
- Controller is with MODBUS for BMS communication
- Controller is having dedicated software to suit application needs; however can be modified according to customer needs thus giving more flexibility in control system
- As a standard, Controller is capable of controlling up to 4 pumps in parallel and as an option can be modified for up to 8 pumps
- Auto take over of pumps and VFDs is possible in case of pump/VFD failure
- Controller takes care of flow requirement by taking inputs from DP sensors across AHUs
- Controller also maintains chiller's minimum and maximum capacity by taking inputs from DP sensors across chiller and temperature sensors at entrance and return and modulating bypass control valve thereby protecting chiller against freezing and allowing staging and de-staging of chiller
- Optional feature like GSM and CDMA support is possible for web based monitoring
- Local/remote control operation is available
- Controller is having flexibility to work with any make of VFD
- Controller is interfaced with chiller panel for staging and de-staging of chiller

Wide Range of Pumps

(End Suction, Back Pull Out Type Long Coupled Pumps)



MODEL: CPHM / DB / CE

- Delivery size: From 20 mm to 200 mm
- Capacity: Up to 1900 m³/hr (8371 US gpm)
- Head: Up to 150 m (493 ft)
- Temperature: (-) 30°C to 90°C
- 50 Hz / 60 Hz availability



MODEL: KPD

- Delivery size: From 20 mm to 200 mm
- Capacity: Up to 750 m³/hr (3304 US gpm)
- Head: Up to 225 m (728 ft)
- Temperature: (-) 50°C to 350°C
- Also available in vertical execution
- 50 Hz / 60 Hz availability

NEW

Zero Leakage Pump



MODEL: iCP

- Delivery size: From 20 mm to 200 mm
- Capacity: Up to 180 m³/hr (793 US gpm)
- Head: Up to 85 m (279 ft)
- Temperature: (-) 30°C to 90°C
- Zero leakage without Mechanical seal / Gland packing
- 50 Hz / 60 Hz availability



MODEL: DBL / MF

- Delivery size: From 150 mm to 650 mm
- Capacity: Up to 7000 m³/hr (30838 US gpm)
- Head: Up to 35 m (119 ft)
- Temperature: (-) 10°C to 90°C
- 50 Hz / 60 Hz availability

Wide Range of Pumps

(Double Suction, Horizontal Axially Split Case Long Coupled Pumps)



MODEL: UP / UPLV / UPH / UPM

- Delivery size: From 50 mm to 1200 mm
- Capacity: Up to 25000 m³/hr (110000 US gpm)
- Head: Up to 180 m (591 ft)
- Temperature: (-) 10°C to 90°C
- 50 Hz / 60 Hz availability



MODEL: SCT / SCT EXTENDED

- Delivery size: From 50 mm to 350 mm
- Capacity: Up to 4500 m³/hr (19813 US gpm)
- Head: Up to 400 m (1313 ft)
- Temperature: (-) 10°C to 100°C
- Highly efficient pump
- 50 Hz / 60 Hz availability

NEW



MODEL: iHT (High speed @ 2900 RPM)

- Delivery Size: From 50 mm to 300 mm
- Capacity: up to 1300 m³/hr (5727 US gpm)
- Head: Up to 250 m (820 ft)
- Temperature: (-) 10°C to 90°C
- Low down time: Quickly fixable
- Space saving as running at 2900 RPM
- Single / double stage pump
- Dual drive
- 50 Hz / 60 Hz availability

Wide Range of Pumps

(Vertical Axially Split Single / Multistage Pumps)



MODEL: iHTV / UPV / SCTV (single/double stage pump)

- Delivery size: From 50 mm to 1200 mm
- Capacity: Up to 25,000 m³/hr (110000 US gpm)
- Head: Up to 160 m (512 ft)
- Temperature: (-) 10°C to 100°C
- 40% space saving against horizontal execution
- 50 HZ / 60 HZ availability

(Vertical Inline Single / Multistage Pumps)

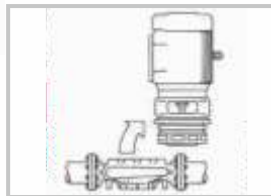

MODEL: SINGLE STAGE (ILS / IN IL)

- Suction - Delivery size: Up to 200 mm
- Capacity: Up to 400 m³/hr (1750 US gpm)
- Head: Up to 90 meter (295 ft)
- Temperature: (-) 30°C TO 90°C
- Back pull-out design
- 50 Hz / 60 Hz availability



MODEL: MULTISTAGE PUMPS (IL / KCIL / KSIL)

- Delivery size: From 25 mm to 100 mm
- Capacity: Up to 110 m³/hr (480 US gpm)
- Head: Up to 250 m (820 ft)
- Temperature: (-) 15°C to 120°C
- Pressed stainless steel components
- All wetted parts in SS304 or SS316

Wide Range of Pumps

(Close Coupled Pumps)



MODEL: DBC (single stage)

- Delivery Size: 125 mm
- Capacity: Up to 350 m³/hr (1540 US gpm)
- Head: Up to 90 m (295 ft)
- Power Rating: 1.5 kW to 75 kW
- Suitable for 415 V (+/- 10 %)
- Back pull out design
- Available in mechanical seal version

(Monobloc Single / Multistage Pumps)



MODEL: KDS + (single stage)

- Delivery Size: 25 mm to 100 mm
- Capacity: Up to 176 m³/hr (778 US gpm)
- Head: Up to 76 m (250 ft)
- Power Rating: 1.5 kW to 22 kW
- Suitable for voltage fluctuation from 300 V to 440 V
- Gland pack / Mechanical seal fitted



MODEL: KDT (multi-stage)

- Delivery size: From 32 mm to 65 mm
- Capacity: Up to 72 m³/hr (318 US gpm)
- Head: Up to 110 m (361 ft)
- Power Rating: 0.75 kW to 15 kW
- Gland pack / Mechanical fitted seal
- Double Stage Pump

Motors



Rotor Balancing



Modern Type Testing Facility

Range and Specifications

- Range : 0.37 kW – 90 kW
- Voltage & Variation : 415 V \pm 10%
- Frequency & Variation : 50 Hz \pm 5%
- Combined Variation : \pm 10%
- Suitable for Ambient Temp. : 50 deg. C
- Operating Duty : S1 Continuous
- Winding Temp. Rise : Limited to Class B
- Insulation : Class "F"
- Enclosure Protection Class : IP 55, TEFC
- Cooling : IC 0141, TEFC
- Mountings : Foot / Foot cum flange/ Flange

Salient Features

- Energy Efficient motors as per EFF1 / EFF2
- Built in efficiencies higher than average of competition in almost all the cases
- Savings on running expenses up to 85% of Total Life Cycle Cost (TLC)

Wide Range of Valves



Check Valves / NRV (Cast Steel)

- Manufacturing Standard: IS 5312 Part 1 & 2 / BS 5153 (EN 12334)
- Size Range : 50 to 1500 mm
 - IS 5312 : 50 to 1500 mm
 - BS 5153 : 50 to 600 mm
- Pressure Ratings : PN 6, PN 10, PN 16
- Material of construction : Cast Iron / Cast Steel / Ductile Iron / 2% NiCr



Sluice Valves / Gate Valves

- Manufacturing Standards : BS 5163 / IS14846
- Type : Metal Seated
- Size Range : (50 to 1400 mm)
- Pressure Ratings : PN 10, PN 16
- End Connections : As per EN/DIN/BS/ANSI standards
- Material of Construction : Cast iron, Ductile Iron, Cast Steel, Stainless Steel



Butterfly Valves

- Manufacturing Standard: IS13095 / EN 593 (BS 5155)/ AWWA C504
- Size Range: Up to 4500 mm
- Design Pattern: Centric, Single Eccentric & Double Eccentric Type
- Pressure Ratings: PN 6, PN 10, PN 16 / AWWA CL - 25, 75, 150 & 250
- End Connections: Wafer, Lug Wafer, Double Flanged – Short/ Long Pattern
- Material of Construction: Cast Iron / Cast Steel / Ductile Iron / Fabricated Steel / 2 % Ni Cast Iron / SG Ni Resist / Duplex Stainless Steel



Ball Valve

- Design and Manufacturing Standard: EN ISO 17292 (BS 5351)
- Size Range: 15 to 300 mm
- Pressure Rating: Class 150 and Class 300
- Operation: Manual Hand Lever (Up to 100 mm) Manual Gearbox (150 mm and above) Electrical and Pneumatic Actuators with accessories and Manual Override
- End Connections: As per ASME B16.5 - 2003 Class 150 / 300

Floor Mounted Composite Control Panel

HMI MOUNTED ON PANEL DOOR

- Two line 20 characters or four line 20 characters
- Blue backlit LED with white text self prompting display
- Soft touch membrane keypad user friendly display enables operator / maintenance personal view
- Alarm messages and parameters like pump status, run hours, kW, set pressure, actual pressure etc.
- Setting of parameters like set pressure, pump configuration other system parameters enables engineer to set up the system



CONTROL PANEL ENCLOSURE

- Enclosure 16/14 gauge CRCA sheet
- Equivalent to IP42
- Removable gland plate for cable entry at bottom
- Ventilation by fan & air filters
- Phase reverse, Phase failure & under voltage relay provided
- SMPS provided to take care of supply voltage variations 85V - 265V Ac.
- Isolation transformer provided to take care of PLC
- Push in type connectors used for connecting field cables for reliability
- LED indicators provided for main phase indication, pump on & trip indication
- Individual Pump on/off push buttons are provided for manual operation along with auto/manual selector switch

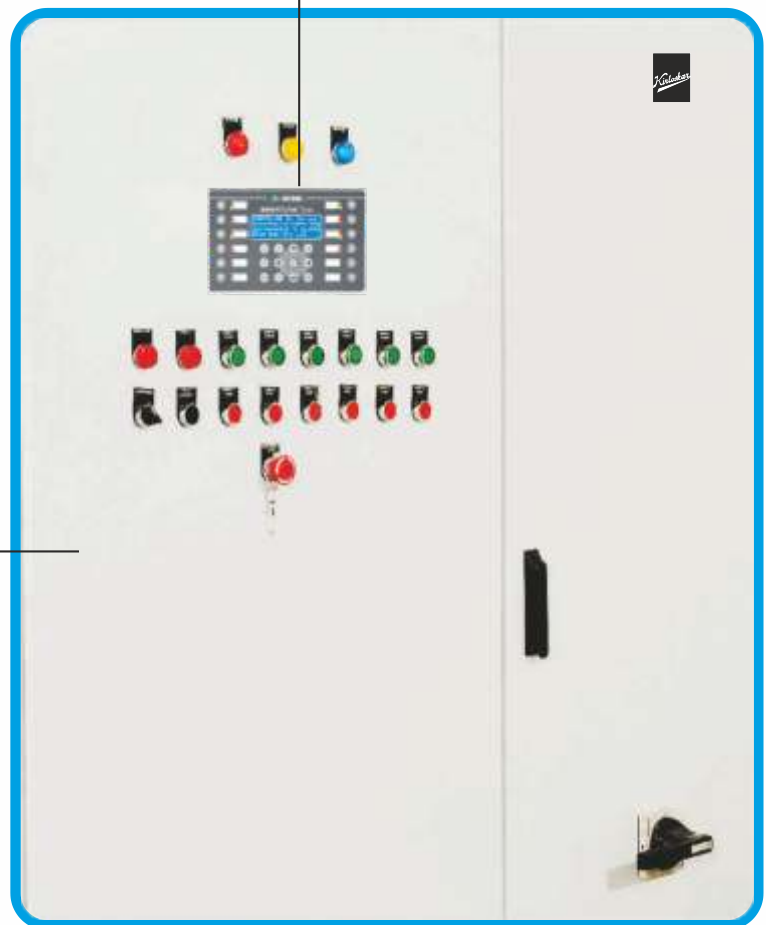

OUTER VIEW OF PANEL

Floor Mounted Composite Control Panel

VARIABLE FREQUENCY DRIVE (any make)

- UL listed PWM technology
- Adjustable acceleration / deceleration time
- User friendly keypad / display unit
- Enclosure IP 21 or IP 54
- Motor overload short circuit protection
- RS 485 port for PLC / BMS
- Communication information to BMS



Display of parameters

- Frequency
- Voltage
- Current KWH
- Faults

PLC (PROGRAMMABLE LOGIC CONTROLLER)

Compatible with any make VFD



- Modular PLC gives flexibility to add Inputs/Outputs as per requirement
- Built in mod bus communications for BMS connectivity. Others like N2 / Bacnet on request
- Dedicated External PLC enables Lead / Log pump alteration
- Auto takeover of other pump in case of failure of working pump
- Number of DPTs can be added as required speed variation by DID
- Provision to connect flow sensor proven program safeguards against dry run, end of curve, pump surge, hunting, over pressure
- Programmable set point with respect to time is possible
- Can work with any make of VFD
- GSM/CDMA support
- Signals to BMS via communication
- Pump on/off status
- Individual analogue input
- Set points
- Actual pressure
- Speed, Current, KW, KWH, Run hours for pumps



INNER VIEW OF PANEL

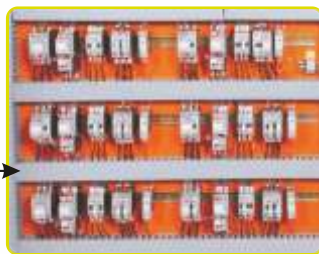

BYPASS STARTER (Optional)



(SFU)
Switch Fuse Unit

Wall Mounted HVAC Controller

Each VFD with inbuilt PLC (Degree of protection IP 54 and IP 21)

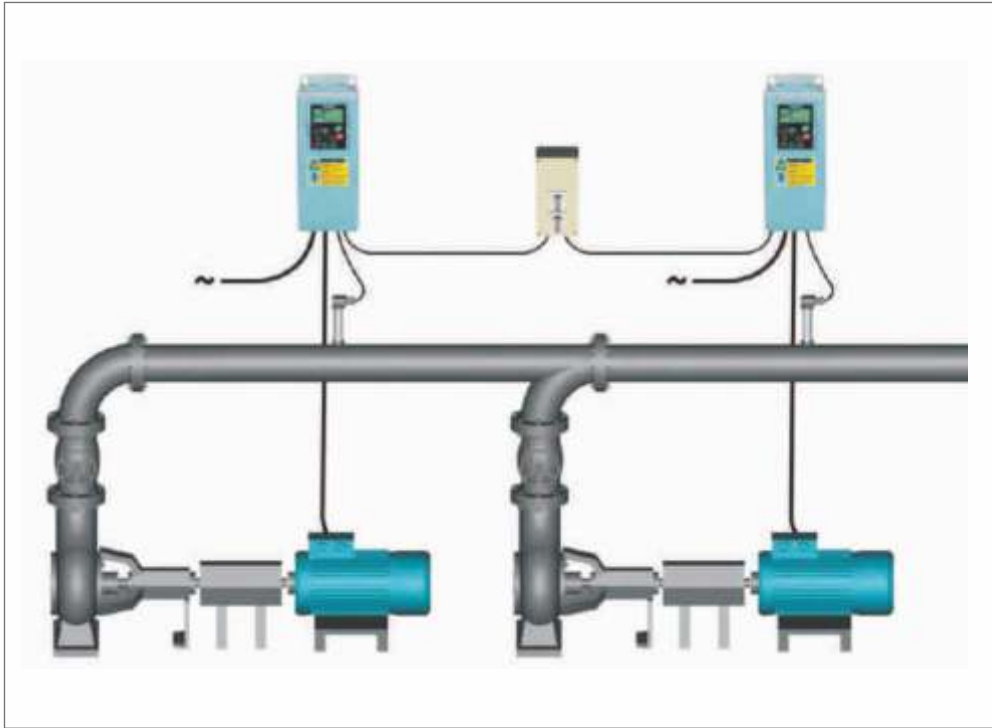

Remote Condition Monitoring of Pumpsets

Web based monitoring of following parameters -

- Flow
- Pressures
- Vibration
- Bearing Temperature
- Voltage
- Current
- Energy Consumption
- Winding Temperature etc.

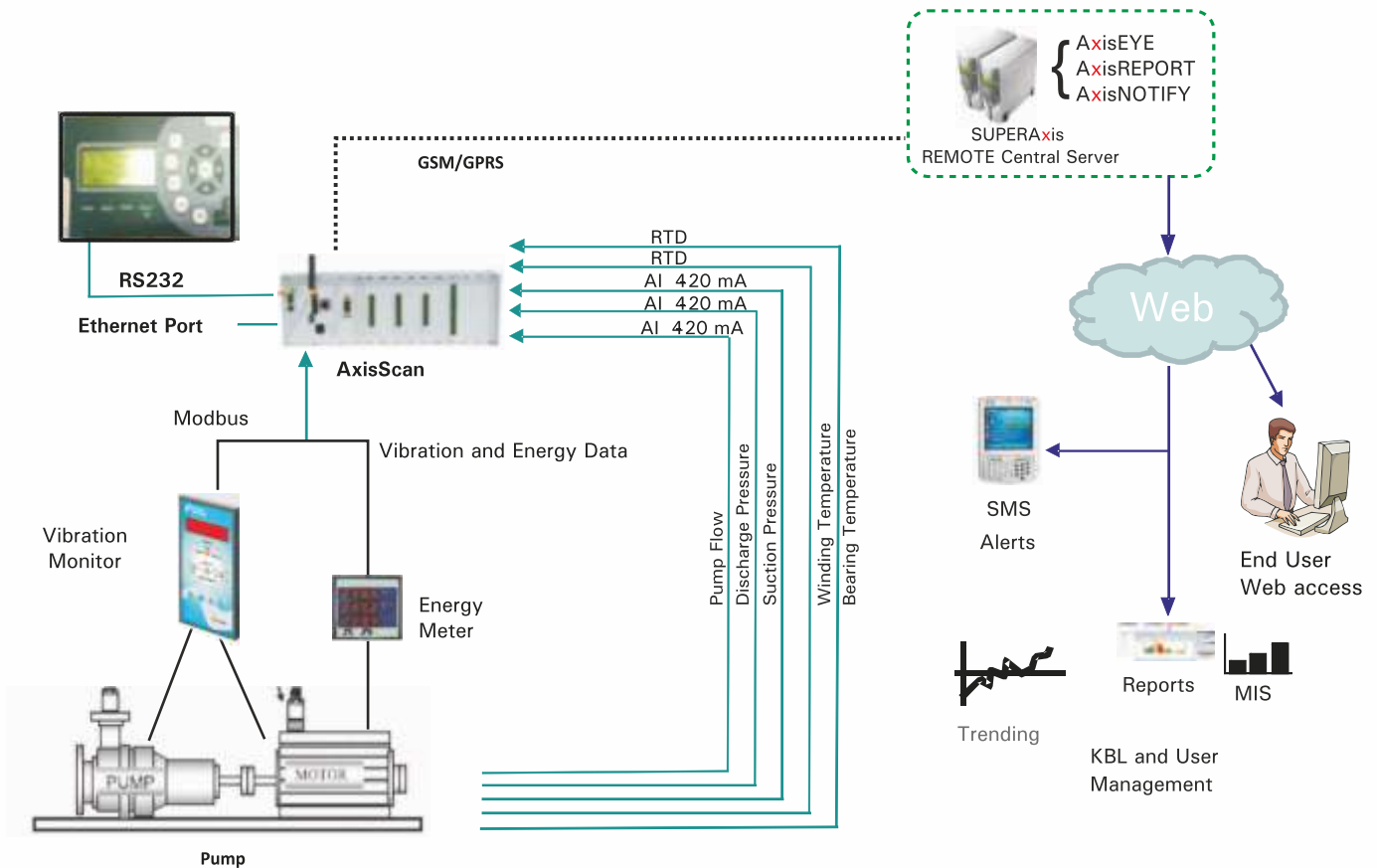

Web Based GPRS Monitoring
(Weekly or Monthly reports can be send for analysis purpose)



Alarm, Alerts and Tentative Action can be informed via sms / mail

Energy Saving Coatings

Why is it required?

1. Improvement of Pump efficiency guaranteed over the existing efficiency at duty point for new Pumps. This improvement will vary from 1 to 3 points based on type of pump and specific speed.
2. Consistency of higher efficiency over its life cycle.
3. Increase in equipment life by manifolds as these coatings are Corrosion, Erosion & Galvanization, abrasion resistant.
4. High reliability, reduction in down time and spare parts requirement.
5. The efficiency of the Pumps will be retained for a longer period as compared to non-coated / epoxy coated Pumps. The efficiency of the coated Pumps is expected to remain constant for atleast 3 years whereas there will be drop in efficiency of uncoated Pump by atleast @ 0.75 to 1% per year.
6. Prevents fungal / microbial growth on the wetted surfaces.
7. Saving in energy bill.
8. Improvement in efficiency over and above the achievable efficiency from Hydraulic point of view without changing the running clearance. The running clearances will remain standard without effecting the reliability. Hence, efficiency improvement is mainly because of reduction in hydraulic losses. (Less friction loss, eddies and suppressed boundary layer).
9. Most Effective Techno-Economic Solution.
10. Potable Water Certification available.



Casing



Impeller



Valve



Tank



Pipes



How it Benefits?

- Smoothens the surface from $18.8 \mu\text{m}$ to $0.08 \mu\text{m}$, which reduces the frictional losses which in-turn enhances and sustains the efficiencies of pumps.

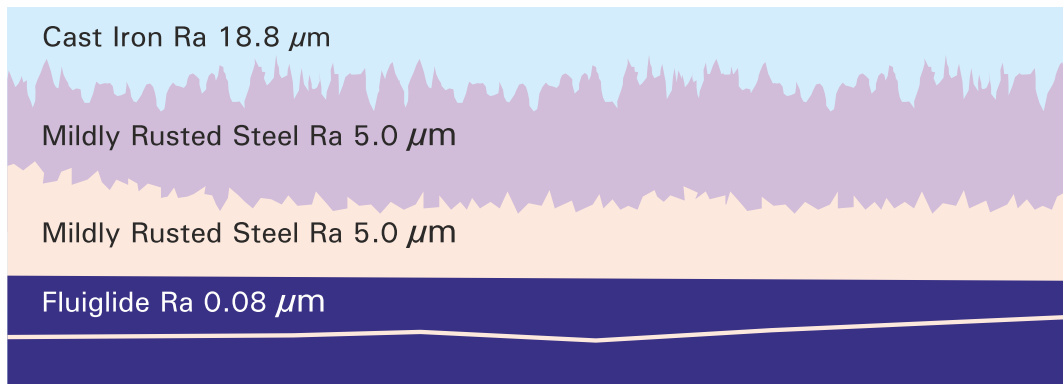

- Hydrophobic in nature

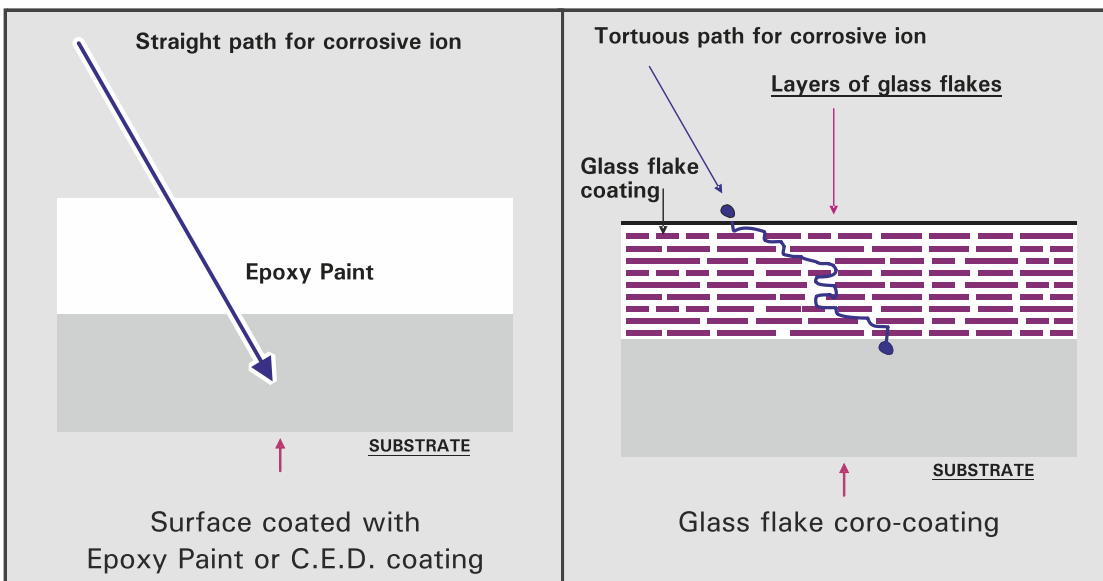
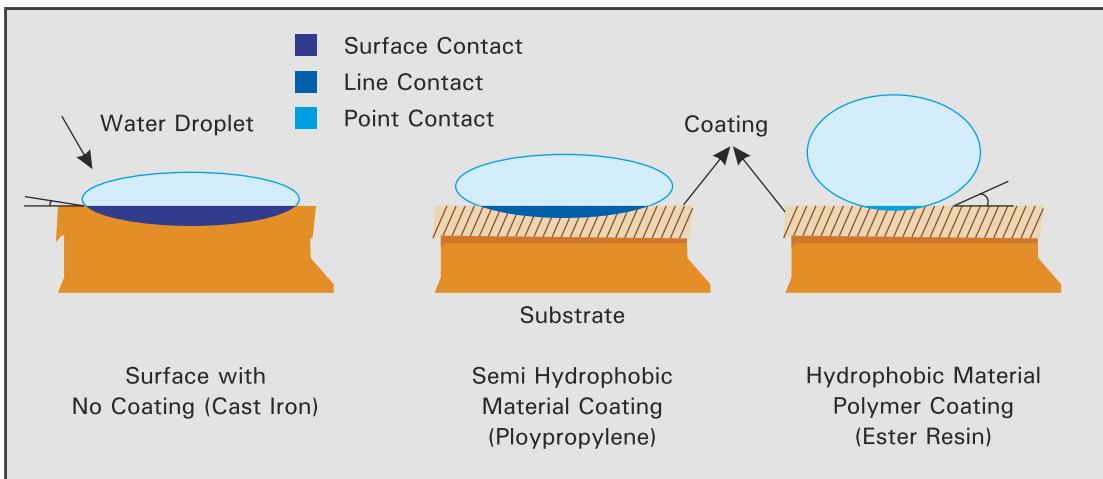

Performance after Coating

ENERGY SAVING

Basic criteria for energy conservation

- To enhance the efficiency above the designed efficiency
- To retain the enhanced efficiency for longer period

A 30 kW Pumpset Case

No of Years	Efficiency (*)	Pumping Cost ₹ Per Annum	Efficiency-Corrocoated Pump (*)	Pumping Cost of Corrocoated Pump ₹ Per Annum	Reduction in Pumping Cost Due to Corrocoating ₹ Per Annum
1	80%	16,06,793	82.00%	15,67,603	32,211
2	79%	16,27,133	81.90%	15,69,517	47,355
3	78%	16,47,993	81.80%	15,71,436	62,924
4	77%	16,69,396	81.70%	15,73,360	78,934
5	76%	16,91,362	81.60%	15,75,288	95,403
6	75%	17,13,913	81.50%	15,77,221	1,12,350
7	74%	17,37,074	81.40%	15,79,158	1,29,794
8	73%	17,60,870	81.30%	15,81,101	1,47,755
9	72%	17,85,326	81.20%	15,83,048	1,66,256
10	71%	18,10,472	81.10%	15,85,000	1,85,319
Total					10,58,301

Considering a project of minimum 10 pumps (30 kW each) working for 10 years, savings would be more than ₹ 1 crore (\$ 0.22 Mn) approx.

IMPROVED COMPONENT LIFE



Non Coated Impeller After 4 years in a typical application

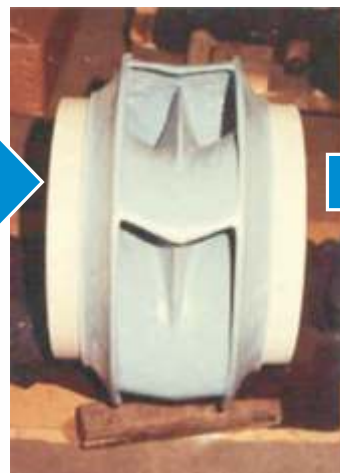

After Refurbishment with Corrocoat Corroglass

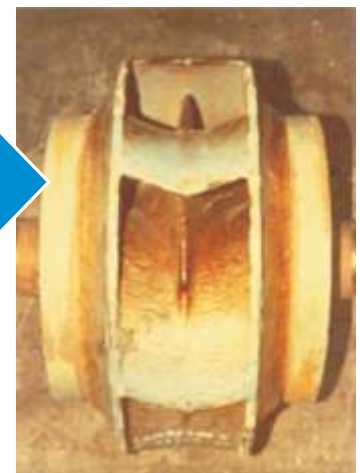
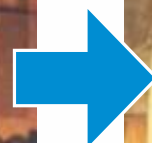

Coated Impeller After 7 Years Service

Pumps for Green Buildings



Energy Efficient and Low Maintenance Cost Series Pumps Component Life Increased

Down Time Reduced

- Benefits generally post installation
- Bearing and Mechanical Seal replacement in Horizontal Split Case Pumps without removing top half and disturbing the rotating unit assembly

Energy Cost Reduced

- Designed for 20 years of life
- All wetted parts with Glass Flake & Energy Saving Coatings
- Pumps designed for higher efficiencies

Maintenance Cost Reduced

- Universal Seal Chamber as per customer specified mechanical seals
- Designed to prevent overloading and motor burning
- Dynamically balanced rotating parts ensuring minimum vibrations

REMOVE GUARD
REMOVE SPACER

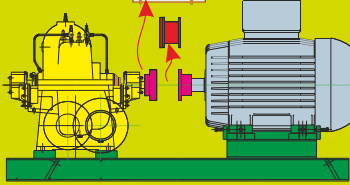

Step 1

REMOVE PUMP COUPLING
REMOVE BEARING HOUSING

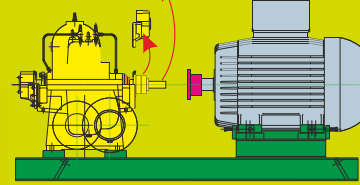

Step 2

REASSEMBLE FOR USE

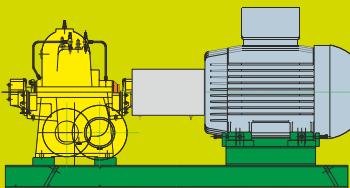

Step 4

REMOVE BEARING
RETAINING NUT REMOVE BEARINGS AND
REMOVE MECHANICAL SEAL

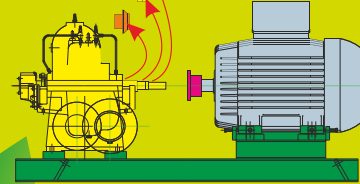

Step 3



District Cooling System

A District Cooling System consists of three primary components: the central plant, the distribution network and the consumer system. The central plant may include the cooling equipment, power generation and thermal storage. The distribution or piping network is often the most expensive portion of the DCS and warrants careful design to optimize its use.

Our Solutions

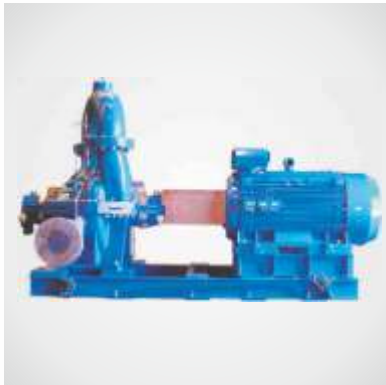

Capacity: Up to 25000 m³/hr (110000 US gpm)
Head: Up to 400 m (1313 ft)



Capacity: Up to 7000 m³/hr (30838 US gpm)
Head: Up to 35 m (119 ft)



Butterfly valve with corocoating



Pipes with corocoating



Central Controller

Major HVAC Customers

Major National Customers



Major International Customers

Middle East Region:

- Saudi Japanese Textile Mills
- Seidco General Contracting LLC
- Modern Bakery
- Al Fanar LLC

South East Asia Region:

Primary Variable Flow Customers

- OCBC Bank
- Turf City
- Great World City
- Bedok Theatre
- G-Energy Consultants
- Aircon Network
- Guthrie Engg
- Great Resources Construction

After Sales Service

24X7 Service Backup



Warranty Period Maintenance



On Call Services



Overhauling



AMC



Operation and Maintenance Management



Spares and Consumables



Energy Cum System Audits



Economy Club



Facility Management



Equipment Modification



System Upgradation

Our Manufacturing Facilities at a glance

Industrial & Engineered Pumps



Kirloskarvadi – Western India

Agricultural & Domestic Pumps



Dewas – Central India

Stainless Steel Borewell Submersible Pumps



Shirval – Western India

Valves



Kondhapuri – Western India



Reading, UK



Colford, UK



Atlanta, USA



South Africa

Foundry & Machining Facilities



A large pump component
being poured



CNC vertical borer
with milling spindle



Fully automatic twin spindle,
twin turret machine



Horizontal machining
center



Vertical machining center
with pallet hanger



Enriching Lives

KIRLOSKAR BROTHERS LIMITED

A Kirloskar Group Company

Established 1888

GLOBAL HEADQUARTERS

“Yamuna”, S. No. 98/3 to 7, Baner, Pune - 411045, India
Phone: +91-20-27214444 Email: kblin@kbl.co.in

REGISTERED OFFICE

Udyog Bhavan, Tilak Road, Pune - 411002, India
Phone: +91-20-24440156 Fax: +91-24440156

GLOBAL PRESENCE

Cambodia | Egypt | India | Lao PDR | Senegal | South Africa | Thailand | The Netherlands
| United Arab Emirates | United Kingdom | United States of America | Vietnam

www.kirloskarpumps.com

OUR COMPANIES



United Kingdom



U.S.A.



South Africa



India



The Netherlands